

Series 3 Power Screen

(Recessed Mount)

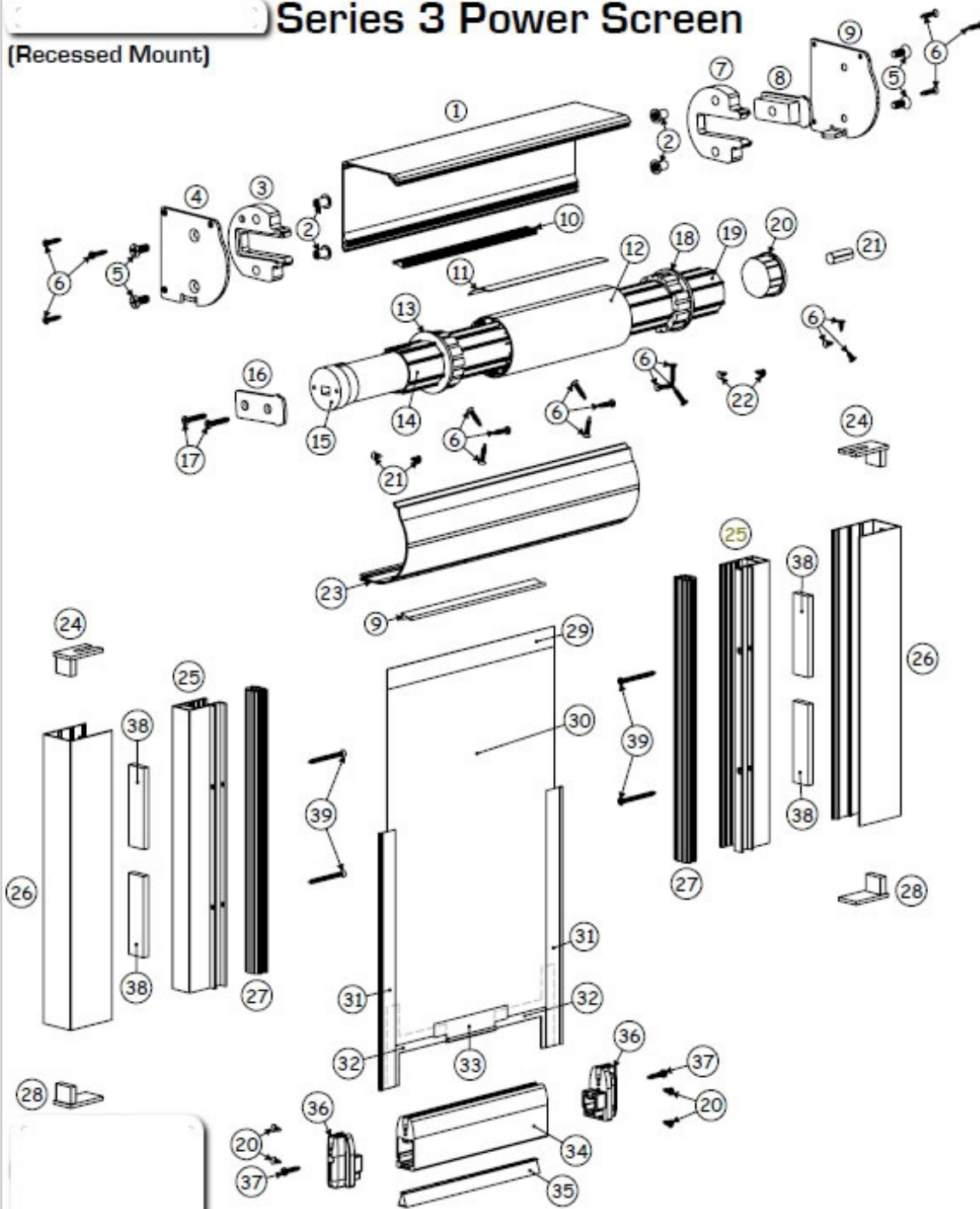

Part Reference	Qty	Description
1	1	Series 3 Housing Base
2	4	1/4"-20X1/2" Knurled Insert
3	1	Series 3 Left Roller Mount
4	1	Series 3 Left Housing End Cap
5	4	1/4"-20X5/8" Flat Head Screw
6	22	6-20X3/4" Self Drill Flat Head Screw
7	1	Series 3 Right Hand Roller Mount
8	1	Series 3 Idler Mount
9	1	Series 3 Right Housing End Cap
10	2	Series 3 Housing Brush
11	1	Adhesive Hook
12	1	Series 3 Outer Roller Tube
13	1	Series 3 Roller Tube Gudgeon
14	1	Series 3 Inner Roller Tube (Motor)
15	1	Motor
16	1	Series 3 Motor Drive
17	2	8-32X1" Flat Head Self Thread Screw
18	1	Series 3 Roller Tube Gudgeon (Mirror)
19	1	Series 3 Inner Roller Tube (Idler)
20	1	Series 3 Idler Cap
21	1	3/8" Tapered Pin
22	8	#6X3/8" Flat Head Top Screw
23	1	Series 3 Housing Cover
24	2	Recessed Side Track Top Cap
25	2	Recessed Side Track
26	2	Recessed Side Track Cover
27	2	PVC Side Track Retainer
28	2	Recessed Side Track Bottom Cap
29	1	Sewn Loop
30	1	Screen Fabric
31	2	Vertical Zipper
32	2	Reinforcement Tab
33	1	Horizontal Zipper
34	1	Hem Bar
35	1	Hem Bar Brush
36	2	Hem Bar End Cap
37	2	6-20X3/4" Self Drill Pan Head Screw
38	TBD*	1/2" Thick Adhesive Foam
39	TBD*	#6X1-3/4" Flat Head Sheet Screw

*Quantity is determined by the height of the unit.